

XPLORER 4K

User Manual

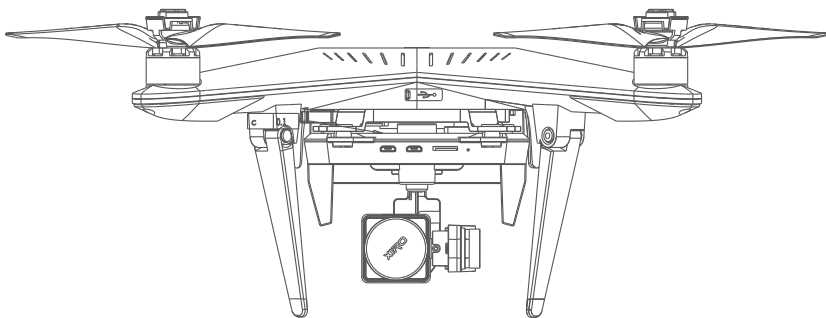

XIRO

- XIRO Customer Support Mainland China:
- XIRO Service Center Hong Kong:
- XIRO Service Center Taiwan:
- XIRO Service Center North America:
- XIRO Service Center Europe:
- XIRO Customer Support Asia:
- XIRO Service Center Oceania:
- XIRO Service Center Other Area:

<as-cn@xirodrone.com>
<as-hk@xirodrone.com>
<as-asia@xirodrone.com>
<as-usa@xirodrone.com>
<as-europe@xirodrone.com>
<as-asia@xirodrone.com>
<as-au@xirodrone.com>
<as@xirodrone.com>

Content

1	Video tutorials and the XIRO App	
	Video tutorials -----	3
	XIRO App -----	3
	Register and login -----	3
2	The Xplorer	
	Xplorer parts overview -----	4
	checking/ charging battery capacity -----	4
	Xplorer assembly -----	9
3	Xplorer functions overview	
	Parts and their functions -----	9
	Remote control -----	9
4	Flight (without gimbal)	
	Flight environment requirements -----	14
	Preflight checklist -----	14
	Magnetic compass calibration -----	15
	Flight test -----	17

Content

5 Aerial photography

Aerial photography tips	19
Gimbal and camera	19
Installing your gimbal	20
Flight test	20

6 Hints and Tips

Warning notice	22
Maintenance tips	22
Smart flight battery safety guideline	22
The Lost-connection protection	23
The Lost-connection protection in Attitude flight mode	23
Low battery level warning function	23

7 Advanced Operation

Switching the remote control compliance configuration mode (FCC/CE)----	24
Pairing the remote control with the Xplorer	24
Switching remote control operating mode	25
Reset the Wi-Fi range extender	25
Connecting the Wi-Fi range extender to the camera	26
Calibrating the gimbal	27

Video tutorials and the XIRO App

1

Video tutorials

- Watch the XIRO video tutorials before your first flight and make sure you feel safe to fly the Xplorer. You can scan the QR code to watch the video tutorials or find the videos on <http://www.xirodrone.com/support>.

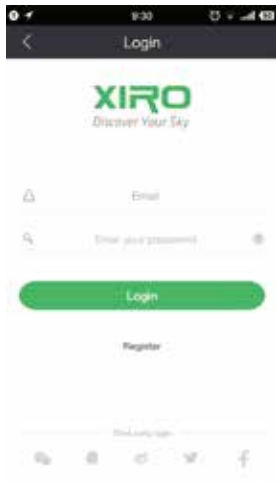

Download and install the XIRO App

- Scan the QR code below to download and install the latest version of the XIRO App.



Android users can download the XIRO App from the Google Play Store. iOS users can download the XIRO App from the Apple App Store.

Note: Scan the QR code here to know more about the XIRO App.



Register and login

- Open your XIRO App, register your XIRO account, login and start aerial photography.

For iOS 8.0 & Android 4.4 +

For the most accurate info on email and hotline contact, we advise you to always check the support pages on <http://xirodrone.com/support>.

Checking the remaining remote control capacity

Power on the remote control, the current power level of the remote control will be shown.



Power indicator

 Battery status: Normal

 Battery status: Low

Charging

 Charge the smart flight battery and remote control after opening the packaging.

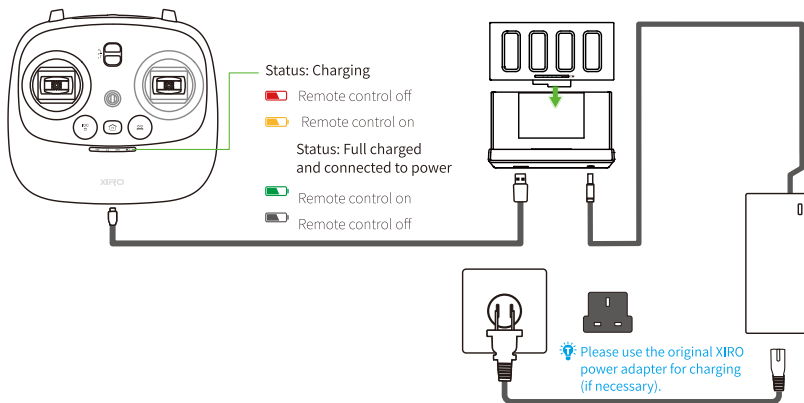

 Voltage range/frequency: 100-240V AC, 50/60Hz
Please use the original XIRO power adaptor for charging.

Xplorer assembly

Installing the smart flight battery

Step1 Turn your Xplorer on its back on a flat surface. Pair the connector of the battery with the pin slot.

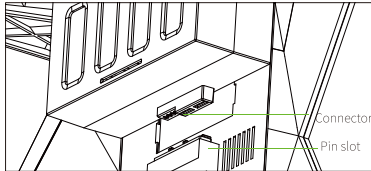

Step2 Check that the battery is inserted fully flat to the bottom of the Xplorer.

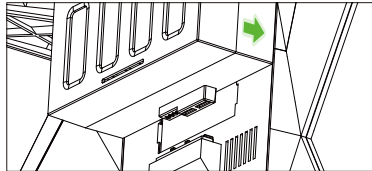

Step3 Push the battery towards the direction of the green arrow until it is locked.

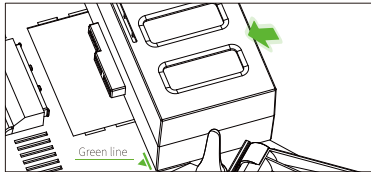

Step4 Push down the battery lock. The battery is locked when the lock is at level with the green line.

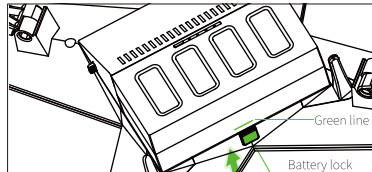

! Make sure the smart flight battery is firmly installed, fully flat to the bottom. Otherwise it may become detached during flight and causing the Xplorer to crash. A crash caused by a not correctly installed battery is not covered by our product warranty.

Removing the smart flight battery

Step1 Push the battery lock towards the green arrow.

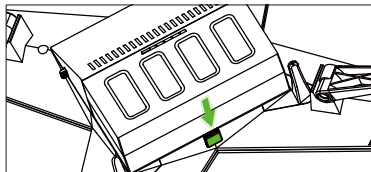

Step2 Push the battery backwards in the direction of the green arrow

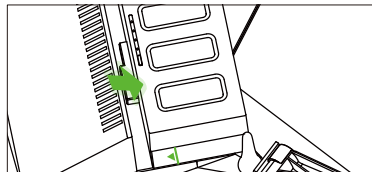

Mounting the propellers

Step1 Mount the silver propellers on the silver motors and the black propellers on the black motors.

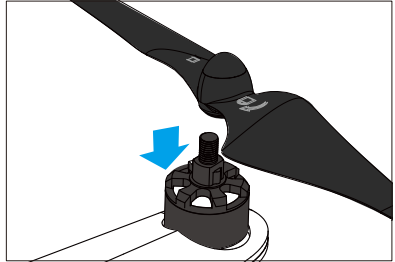
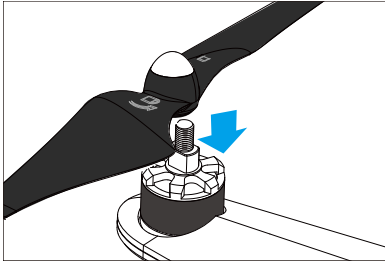

Step2 Tighten the silver propellers by spinning counter-clockwise and tighten the black propellers by spinning clockwise.

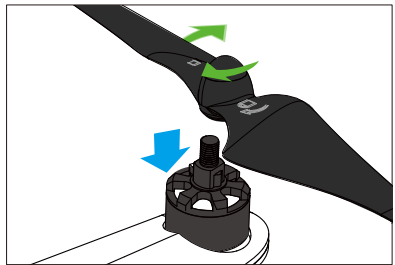
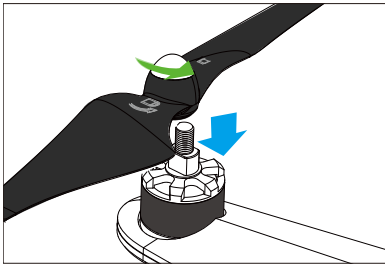

Note:

1. Check if the propellers are mounted correctly and firmly. They are self tightening during flight.
2. Do not use damaged or broken propellers.
3. Keep a safe distance and do not touch propellers or motors while spinning.
4. Use original XIRO propellers for a safe and relaxed flight experience.
5. The edges of the propellers can become sharp, be careful when installing and removing the propellers.

Removing the propellers

Step1 Keep the motors fixed with one hand, spin it according to the un-lock direction as marked on the propellers.

Step2 Remove the propellers.

Attaching the propeller guards (Sold separately)

For extra safety, pilots are recommended to use the propeller guards. More detailed instructions are included in the packaging of propeller guards. Please contact your local XIRO authorized dealer or visit the XIRO website on <http://www.xirodrone.com> to buy the propeller guards.

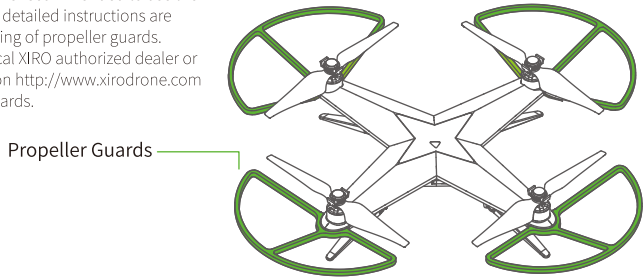

Installing the Wi-Fi range extender

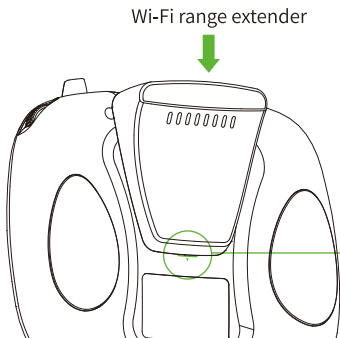

- Step 1** Turn off the remote control.
- Step 2** Align the range extender with the green line on the back of your remote control.
- Step 3** Push the range extender downwards until it is fixed.
- Step 4** Power on the remote control. When the Wi-Fi connection indicator turns red, the range extender is installed successfully.

Xplorer functions overview

3

The Xplorer

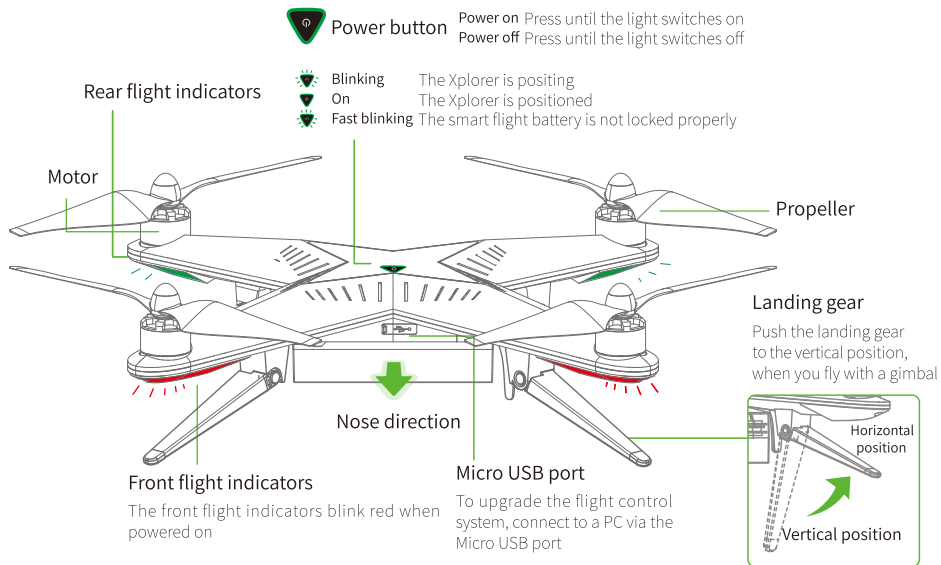

Rear flight indicators (Status: abnormal)	
	Return home / Disconnected with RC
	Battery level is low (Return home ASAP)
	Battery level is critical (Descend slow)
	GPS failure (Restart required)
	Compass failure (Recalibration required)
	Gimbal connection failure (Remount the gimbal)
	You can not start the Xplorer in the attitude flight mode in flight level 1.
	Sensor data is abnormal (Please return home)

Rear flight indicators (Status: normal)	
	Status:Checking
	GPS flight mode
	IOC (headless) mode
	Attitude flight mode (no GPS)

GPS flight mode When more than 6 GPS satellites are available, the rear flight indicators blink green slowly. The Xplorer is now ready to fly safely, all smart functions based on GPS positioning are available.

Attitude flight mode When less than 6 GPS satellites are available, the rear flight indicators blink yellow slowly. The Xplorer is now less safe, all functions based on GPS positioning like e.g. Auto Home, Auto Landing and Follow Me/Snap are not available.

Remote control

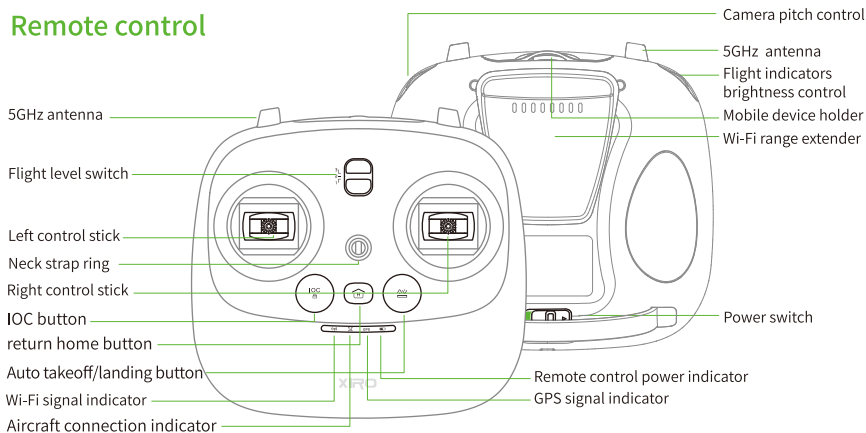

Functions of the remote control

Buttons / Parts	Functions
Power button	Power switch for the remote control
Left control stick and right control stick	Control the throttle, yaw, rolling and pitching of the Xplorer
Camera pitch control	To operate the pitching angle of the camera
Flight indicators brightness control	To control the brightness of Xplorer's LED lights
Flight level switch	To select your flight level (level 1, level 2, level 3)
IOC button	To select IOC mode. Attention does not function in a non GPS flight mode.
Return home button	One-key return home. Attention does not function in a non GPS flight mode.
Auto takeoff/landing button	One-key takeoff / landing. Attention does not function in a non GPS flight mode.
Mobile device holder	Supports your mobile device (Max. width: 73mm, supports mobile devices up to 5.5" screen)
Neck strap ring	To connect your neck strap with the remote control
Micro USB port	For calibrating and charging the remote control





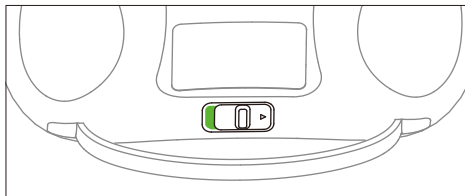

The power switch

Push the Power Switch to ON to power on the remote control.

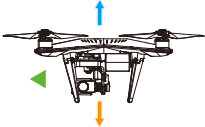

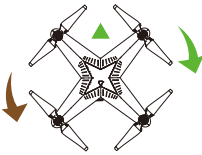
Control Stick

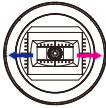
The remote control is set to mode 2 by default. This user manual will explain how to operate the remote control in its default setting Mode 2.

Remote Control (mode 2)	The Xplorer ◀ (Nose direction)	Operating steps:
 <p data-bbox="156 397 249 411">Left control stick</p>		<p>Throttle control (left control stick): Move the stick forward or backward to control the power on all four engines simultaneously. This will cause the Xplorer to climb or descend. Wait until the motors are fully started. Then push up the stick slowly forward, the Xplorer will go upwards. Pull the stick slowly backwards to go downwards. Moving the stick more forward or backward will increase the speed of the Xplorer.</p>
 <p data-bbox="156 639 249 653">Left control stick</p>		<p>Yaw control (left control stick): Yaw is the aviation term for spinning your Xplorer around its axis. Move the stick to the left or right to control the spinning direction. During the flight, slowly move the stick to left and the Xplorer will rotate counter clockwise, slowly move the stick to right then the Xplorer will rotate clockwise. Moving the stick more forward or backward will increase the rotating speed of the Xplorer.</p>
 <p data-bbox="151 841 252 854">Right control stick</p>		<p>Pitch stick (right control stick): Move the stick forward or backward to control the forward or backward flying direction. During the flight, slowly push the stick forward and the Xplorer flies forward, slowly pull the stick back then it flies backward. Moving the stick more forward or backward will increase the flying speed of the Xplorer.</p>
 <p data-bbox="156 1042 249 1056">Right control stick</p>		<p>Rolling Stick (right control stick): Move the stick to left or right to control the left or right flying direction. During the flight, slowly move the stick to left and the Xplorer will fly to its left, slowly move the stick to right then the Xplorer will fly to its right. Moving the stick more forward or backward will increase the flying speed of the Xplorer.</p>

Flight indicators brightness control

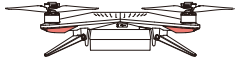

Camera pitch control

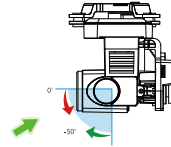

○ Flight indicators brightness control

Use the left scroll wheel on the remote control to adjust the brightness of the flight indicators.

○ Camera pitch control

Use the scroll wheel on the right side of the remote control to adjust the tilting angle of the camera. Tilting range can vary from -90° up to 0 . The more you scroll the wheel the more you will increase the speed of tilting the camera. When you release the scroll wheel, it will go back to its original position and the camera will keep its new angle.

☰ Flight level switch

You can use 3 different flight levels each with different max. flying speeds and a different max. flight range.

Options	1	2	3
Altitude (m)	50	120	300
Distance (m)	100	300	1000
Horizontal speed (m/s)	2	6	12
Vertical speed (m/s)	2	2	3
Attitude flight mode	Not available	✓	✓
GPS mode	✓	✓	✓
IOC (headless) mode	✓	✓	✓
One-key return home	✓	✓	✓

1. It is advised to start flying at Level 1. When you are more confident and more experienced you can increase your flying speed and flight range.
2. The Xplorer will change its max. flight speed, altitude and distance based upon the chosen flight level. Please be careful when changing the flight levels.

Intelligent flight mode buttons

IOC (headless) mode

-  When you press this button down you start the IOC mode. When you press the button again, you will exit the IOC mode. In GPS flight mode, when you press “IOC”, the Xplorer will use its HOME point as reference for its orientation. Pull the stick backward: the Xplorer will fly towards HOME point and vice versa. The front of the Xplorer (the red flight indicators) is no longer important for controlling the flight direction of the Xplorer.

HOME point The GPS position of the Xplorer when the Xplorer is powered on and took off in GPS mode.

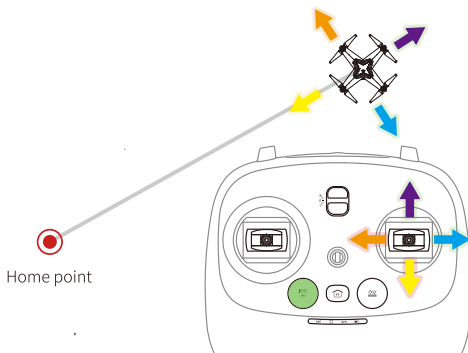

Return home mode

-  Press this button to have your Xplorer automatically return to its HOME point based on an auto pilot route. Press the button again to exit return home mode.

When the horizontal distance between the HOME point and the Xplorer's position is less than 25 meters or its height is more than 20 meters, the Xplorer will fly back to HOME point at current height and land smoothly.

When the distance between HOME point and Xplorer's position is more than 25 meters and its height is less than 20 meters, the Xplorer will first climb to 20 meters and then fly back to its HOME point.

The flight indicators turn to solid red during returning.

Auto takeoff/landing

-  Auto takeoff Start the motors and press this button, the Xplorer will slowly climb and stops hovering at approx. 3 meters height and waiting for your control.

landing: Press this button during the flight, the Xplorer will auto land and shut off its motors.



Always use auto takeoff or auto landing when flying with the gimbal attached. It is the most safe way not to damage your delicate and expensive gimbal. Most damages occur during takeoff or landing of the Xplorer.



1. All the functions based on GPS positioning, can only be used in a GPS flight mode, such as IOC flight mode, auto return home, auto takeoff/landing.
2. Pay attention to the ground condition of the area you select for landing to avoid damage on your Xplorer caused by obstacles and/or uneven ground level.

Flight (without gimbal)

4

⚠ Flying your Xplorer safely and damage free requires some experience. It is advised not to fly with your gimbal attached when performing training flights. The gimbal is an expensive and delicate part of your Xplorer, avoid any risk of damaging your gimbal / camera.

Flight environment requirements

- Before every flight, check the local airspace laws and regulations regarding remote controlled aircrafts and follow these at all times.
- Ensure to fly outside a radius of 3 km of any airport or governmental buildings.
- Always fly in open areas and away from people and property. Do not fly directly over people or animals.
- Avoid flying in areas that may cause magnetic interference, such as: power lines, tall buildings, shopping malls, residential areas or mines, to avoid malfunctioning of the magnetic compass in your Xplorer.
- Fly below 4000 meter above sealevel to avoid problems with the ascending power in your Xplorer due to the low air pressure at that height.
- Check your local UAV weather forecast for information on atmospheric factors that can interfere with controlling your Xplorer. Factors like GPS availability and solar flares can cause unexpected behaviour of your Xplorer. Fly your Xplorer only with a wind force 4 or below and stay out of weather conditions like rain, snow or fog.
- The Xplorer 4K is equipped with GPS positioning for flying outdoors. Flying indoors requires advanced skills to control your Xplorer and avoid accidental damage.

Preflight checklist

1. The smart flight battery and the remote control have to be fully charged. When the battery capacity is low, charge the battery or use a fully charged battery.
2. The smart flight battery has to be secured fully flat to the bottom of the Xplorer and locked correctly.
3. The propellers are mounted firmly.
4. The landing gear is in the low, horizontal position (See more functional details on page 9).

Magnetic compass calibration

Calibration procedure

1. Remove the propellers, power on the remote control, followed by powering on the Xplorer. Hold the button until the light is switched on.

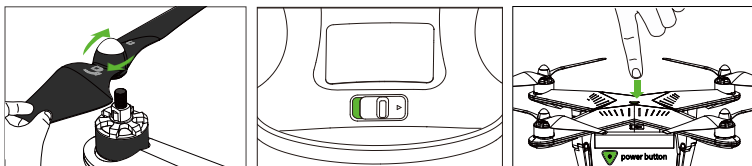

2. Wait until the rear flight indicators blink green slowly (GPS flight mode) or yellow slowly (Attitude flight mode).

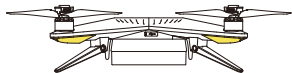

Indicators blink yellow slowly

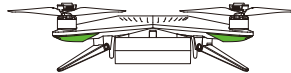

Indicators blink green slowly

3. Pull the throttle stick (the left stick in default mode 2) straight down to its lowest point and keep it in that position. Press the "IOC" button 6 times for 3 On/Off cycles: On-Off-On-Off-On-Off.

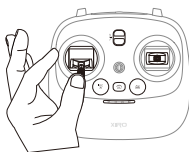

4. The rear flight indicators will turn solid green. You can now release the throttle stick. Hold the Xplorer horizontal with the front pointing outwards (the red flight indicators pointing away from you) and keep it steady at that horizontal position. Slowly rotate 1-3 circles, wait until the rear flight indicators blink yellow fast.



Step 4

⚠ When the rear flight indicators start blinking green fast, the Xplorer is no longer in an exact horizontal position. This may result in having to make more circles to finish this stage of the calibration procedure.

5. For the next stage, hold the Xplorer vertical with the front pointing downwards (the red flight indicators pointing towards the ground) and keep it steady at that vertical position. Slowly rotate 1-3 circles, wait until the rear flight indicators start blinking green or yellow slowly.



Step 5

⚠ When the rear flight indicators start blinking yellow fast, the Xplorer is no longer in an exact vertical position. This may result in having to make more circles to finish this stage of the calibration procedure.

6. The rear flight indicators will blink green slowly or yellow slowly when the calibration procedure ended successfully. The calibration procedure has been unsuccessful when the rear flight indicators blink red and yellow alternately. You have to repeat the calibration procedures to ensure a safe flight.

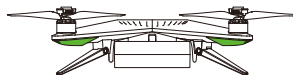

Calibration is successful when lights blink green or yellow slowly.

Flight test

Takeoff preparation

1. Place the Xplorer with the rear flight indicators facing towards you in an open and even area.
Keep a safe distance of a minimum of 5 meters between you and the Xplorer.
2. Select flight level 1, then power on the remote control.
3. Power on the Xplorer and wait until the power button is lightened up.

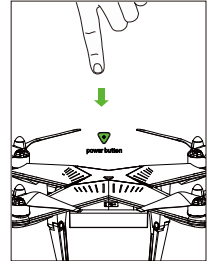
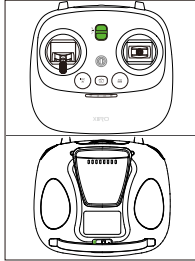
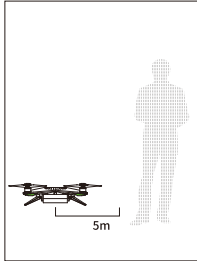

- ⚠** When the rear flight indicators blink green slowly, the Xplorer is in GPS mode. You can now safely use the intelligent flight modes. When the rear flight indicators blink yellow slowly, the Xplorer is in Attitude mode. You can not start your Xplorer in flight mode 1, you have to switch to flight mode 2 or 3. Remember that the auto pilot now can not correct height and position. The attitude flight mode requires a skilled pilot. Do not fly in the attitude mode when you have only limited experience.

Connecting the mobile device

1. Pull the mobile device holder from the top of the remote control and place your mobile device.
2. Enable Wi-Fi on your mobile device, search for the available Wi-Fi networks and then select the network named "XPLOREX_XXXXXX" from your Wi-Fi network list. When requested for a password, enter the default password: XIRO1234.
3. Open the XIRO App on your mobile device and press the button "Start Aerial Photography" to display the flight information of the Xplorer.

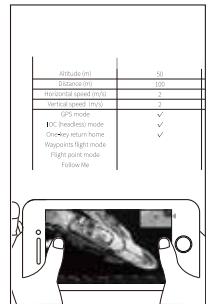
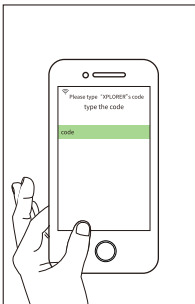
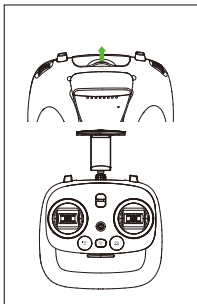

Altitude (m)	00
Distance (m)	000
Horizontal speed (m/s)	0
Vertical speed (m/s)	0
GPS mode	✓
EOC (headless) mode	✓
One-key return home	✓
Waypoints flight mode	✓
Flight point mode	
Follow Me	

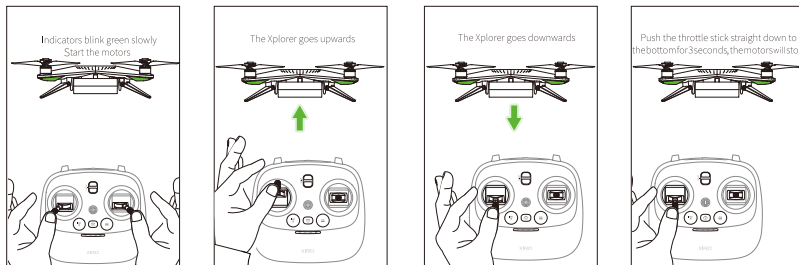

Flight control

1. Ensure yourself that the GPS flight mode is operational, the rear flight indicators will blink green slowly. In default mode 2, push the left stick to the bottom left and simultaneously the right stick to the bottom right position. Your Xplorer will now start.
2. Slowly push the left throttle stick forward to have the Xplorer go upwards smoothly.
3. Slowly pull the left throttle stick backwards to land the Xplorer.
4. When the motors keep running, you can stop the motors by performing the same combination stick command (CSC) used to start the motors. You can also pull the left throttle stick backwards and hold for 3 seconds until the motors stop.





- ⚠️ 1.** Do not fly without having the range extender connected to your mobile device display. Connecting your Wi-Fi range extender to your mobile device and use the XIRO Xplore App to view the flight information, and store the flight track data to your mobile device. This flight track data is critical proof for XIRO customer support services to determine anomalies in flight behavior.
2. After flying the Xplorer, you are advised to learn more advanced flight skills via the Flight training exercises in the XIRO Xplore App.

One-key takeoff

- Step 1 Confirm the Xplorer is in the GPS flight mode and ensure the flight area is safe and open.
- Step 2 Power on the remote control, followed by powering on the Xplorer.
- Step 3 Start the Xplorer motors.
- Step 4 Press the button .
- Step 5 The Xplorer will slowly climb and stop hovering at approx. 3 meters height.
- Step 6 Press the button  again when the Xplorer is hovering stable.

One-key landing

- Step 1 Confirm the Xplorer is in the GPS flight mode and the ground beneath the Xplorer is safe and flat for landing.
- Step 2 Press the button .
- Step 3 The Xplorer will slowly descend, land and shut off the motors.
- Step 4 Press the button  again after the landing is finished.

Aerial photography

5

⚠ Fly with the gimbal when you have finished the Flight training exercises in the XIRO Xplorer App or when you are more experienced in flying Xplorer.

Aerial photography tips

1. Firstly check the flight environment requirements on page 14.
2. Always fly in good, dry and clear weather conditions.
3. You can adjust the camera settings in flight to accommodate your preference.
4. Move the sticks gently to maneuver your Xplorer in a stable and smooth manner for the best result.
5. When the rear flight indicators turn white during the flight, it can be caused by abnormal data of the sensor resulting from the tilting flying angle being too steep or the magnetic interference in the area of your Xplorer being too strong. This can be caused by e.g. power lines, tall buildings, shopping malls or residential areas.

Gimbal and camera

Your Xplorer 4K is featured with an advanced 3-axis stabilized gimbal system with built-in high accuracy sensors and rapid response brushless motors. The gimbal eliminates all vibrations and blurring caused by the wind, motors and movements of your Xplorer. The 4K high-end lens combined with the 1/2.3 Sony image sensor make it possible to take pictures with a 12 megapixel resolution and shoots high definition video at 4k/30fps or 1080p/120fps.

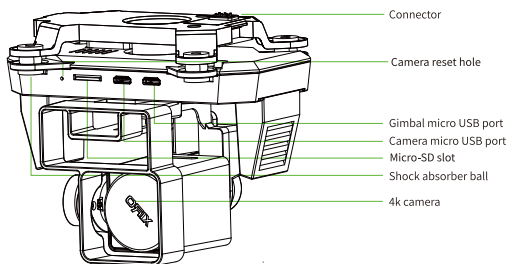

1. Upgrade the gimbal firmware via a USB cable connected to a computer.
2. Upgrade the camera firmware via a USB cable connected to a computer.
3. Supports micro SD cards up to 128Gb.

Installing your gimbal

- Step 1 Put the landing gear in the horizontal downward position and remove the smart flight battery.
- Step 2 Insert the green tip on the gimbal into the green slot on the bottom of the Xplorer.
Adjust the gimbal in line with the gimbal lock and softly press the gimbal into its position.
- Step 3 Push the gimbal until a "click" is heard.
- Step 4 Pull your gimbal lightly upwards to make sure it is locked securely.
- Step 5 Insert the smart flight battery and put the landing gear in the vertical upward position.
- Step 6 Remove the gimbal clamp (Make sure you take off the transport protection clamp before every flight).

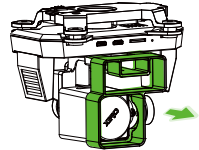
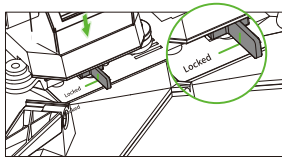
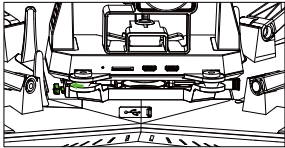

Removing the gimbal

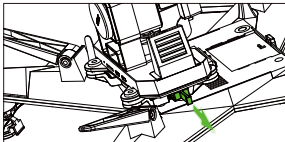

- Step 1 Put the landing gear in the horizontal downward position and remove the smart flight battery.
- Step 2 Pull the gimbal lock stick outwards and then carefully remove the gimbal by moving it to the right.
- Step 3 Do not forget to place the transport protection clamp back onto the gimbal to ensure safe and damage free transport.

Flight test

Takeoff preparation

1. Place the Xplorer with the rear flight indicators facing towards you in an open and even area.
Keep a safe distance of a minimum of 5 meters between you and the Xplorer.
2. Select flight level 1, then power on the remote control.
3. Power on the Xplorer and wait until the power button is lightened up.

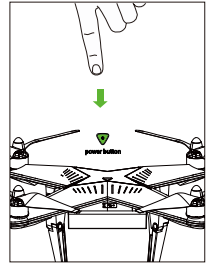
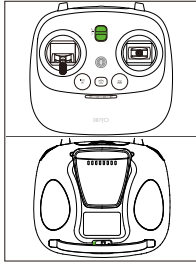
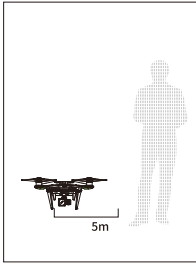

- ⚠** When the rear flight indicators blink green slowly, the Xplorer is in GPS mode. You can now safely use the intelligent flight modes. When the rear flight indicators blink yellow slowly, the Xplorer is in Attitude mode. You can not start your Xplorer in flight mode 1, you have to switch to flight mode 2 or 3. Remember that the auto pilot now can not correct height and position. The attitude flight mode requires a skilled pilot. Do not fly in the attitude mode when you have only limited experience.
- ⚠** Always attach the transport protection clamp back onto the gimbal to protect the delicate parts of your gimbal after each flight. When the pointer is off, the unstabilized, expensive gimbal can easily be damaged.

Connecting the mobile device

1. Pull the mobile device holder from the top of the remote control and place your mobile device.
2. Enable Wi-Fi on your mobile device, search for the available Wi-Fi networks and then select the network named "XPLORER_XXXXXX" from your Wi-Fi network list. When requested for a password, enter the default password: XIRO1234.
3. Open the XIRO App on your mobile device and enter the real-time preview page.

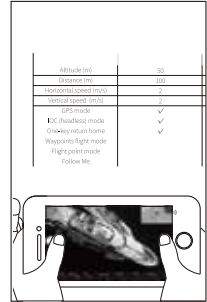
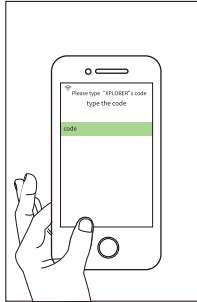
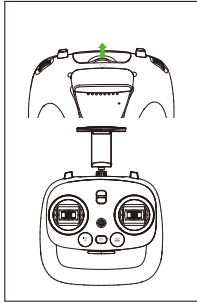

Flight control

1. Ensure yourself that the flight mode is operational, the rear flight indicators will blink green slowly. In default mode 2, push the left stick to the bottom left and simultaneously the right stick to the bottom right position. Your Xplorer will now start.
2. Slowly push the left throttle stick forward to have the Xplorer go upwards smoothly.
3. Slowly pull the left throttle stick backwards to land the Xplorer.
4. When the motors keep running, you can stop the motors by performing the same combination stick command (CSC) to start the motors. You can also pull the left throttle stick backwards and hold for 3 seconds until the motors stop.

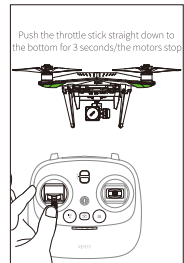
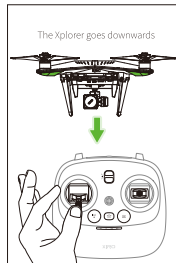
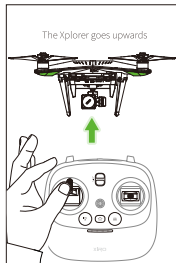

⚠ Do not fly without having the range extender connected to your mobile device. Connecting your Wi-Fi range extender to your mobile device and use the XIRO Xplorer App to display the flight information, and store the flight track data to your mobile device. This flight track data is critical proof for XIRO customer support services to determine anomalies in flight behavior.

Hints and Tips

6

Warning notice

1. Do not use the combination stick command (CSC) to power off the motors during flight. This will cause your Xplorer crash instantly.
2. Do not make panic movements with the control sticks in an attempt to avoid collision. This will often result in more damage and enhanced risks for your environment.

Maintenance tips

1. Store the Xplorer and all parts by normal room temperature and in a dry environment.
2. Do not put heavy objects on top of your Xplorer.

Smart flight battery safety guideline

1. Only use the XIRO smart flight battery and the XIRO charger for the Xplorer. XIRO does not take any responsibility for damages caused by third party batteries or battery chargers.
2. Do not charge a battery that is still warm from usage and never use a battery in your Xplorer that is still warm from charging.
3. Replace the battery when it has been discharged over 300 times.
4. Never recharge or use a (visually) defective battery.
5. When you store your Xplorer for longer period make sure the battery power level is below 50% to optimize its lifespan.
6. Discharge the battery completely once every 20 charge/discharge cycles. This will optimize the battery lifespan.
7. Please deliver used batteries to the designated battery disposal locations in your area.
8. When you come in contact with battery acid, immediately wash your skin or eyes with fresh water for at least 15 minutes and see your doctor instantly.
9. A LiPo battery fire is a chemical fire. Put out the fire by using sand or using a Class D, dry powder fire extinguisher. DO NOT use water!

The Lost-connection protection

When the Xplorer, while in GPS flight mode, loses connection with the remote control, it will stay at the last "connected" position. The Xplorer will try to recover the connection for 3 seconds before automatically return to its HOME point.



⚠ When the Xplorer reconnects with the remote control during the auto return to HOME, it will stop and hover at the reconnection point. The user is able to regain full control.

⚠ XIRO's collision avoidance system is NOT available in the Xplorer 4K. Your Xplorer is not yet capable to avoid obstacles automatically during return home once it lost the connection. DO NOT fully depend on the auto return home function, actively try to regain control again.

The Lost-connection protection in Attitude flight mode

When the Xplorer, while in Attitude flight mode, loses connection with the remote control, it might start to drift away. It will try to reconnect with the remote control continuously. The aircraft will start to descend slowly when the battery power gets low.

⚠ It is advised to move with the remote control into the direction of the Xplorer when the connection is lost in Attitude flight mode. The connection will be re-established faster when the distance is reduced.

Low battery level warning function

Low battery level warning

The Xplorer will trigger the low battery level warning on the remote control when the battery capacity gets low.

Remote control: The remote control starts alternating vibrations.

Xplorer: The rear flight indicator blink red slowly, and the Xplorer status indicator on the remote control turns red.

XIRO App: A warning message: "Return Home? " will appear.

⚠ In GPS Mode, when the remote control vibrates due to critical low power level, you can press the One-key return home button to have the Xplorer return.

Critical Low Battery Level warning

The Xplorer will trigger a critical low battery level warning when the battery capacity is critically low.

Remote Control: You feel continuous vibrations.

Xplorer: The rear flight indicators blink red fast, and the Xplorer status indicator on the remote control turns red.

XIRO App: A warning message " The Xplorer is landing " will appear.

When flying in GPS mode:

The rear flight indicators blink red fast and the Xplorer begin to descend and land automatically if the distance between Xplorer and Home point is less than 100 meters. The Xplorer will automatically return to HOME point when the distance is more than 100 meters.

When flying in Attitude mode:

The rear flight indicators will blink red fast and the aircraft will begin to descend and land automatically.

7. Advanced Operation

7

Following advanced operations describe actions to switch modes of your Xplorer or solve problems that can occur when operating your Xplorer. DO NOT perform these actions unless you are experienced with these actions. Incorrect usage may cause your Xplorer to become not fully operational.

Switching the remote control compliance configuration mode (FCC/CE)

Hold the left control stick in top left position and the right control stick in the top right position, then power on the remote control. The remote control is now in the compliance configuration mode. The current setting will be shown, and the user can move the camera pitch control to switch between the modes. Moving the camera pitch control counter clockwise (up) for FCC and clockwise (down) for CE. The two middle LED indicators turn red in FCC mode and green in CE mode.

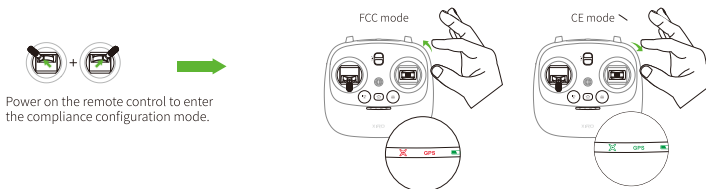

Pairing the remote control with the Xplorer

Hold the left control stick in top right position and the right control stick in the bottom left position, then power on the remote control to pair the remote control. The Wi-Fi signal indicator and GPS indicator on the remote control blink red and green alternately. Use a pin to press the pairing reset button on the bottom of the Xplorer and power on the Xplorer. The remote control will now pair with Xplorer. The remote control will exit the pairing mode automatically once it is paired and the Xplorer connection indicator turns solid green. When not successful, repeat this procedure.

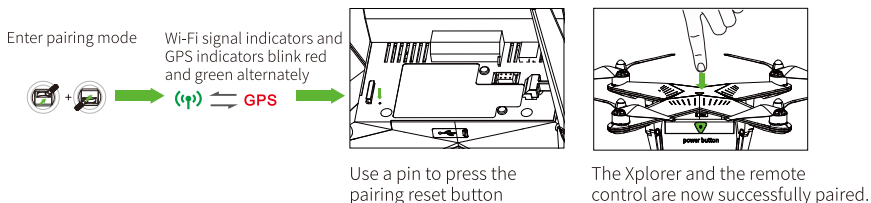

Switching remote control operating mode

Hold the left control stick in bottom right position and the right control stick in the top left position, then power on the remote control to enter the remote control operation configuration mode. Press  to switch modes.

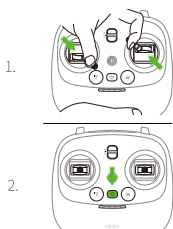

The actual remote control operation mode will be shown once the remote control is in operation configuration mode.

Pilot/ Indicator	Xplorer indicator (Left)	GPS lock indicator (Right)
Mode 1 (Japanese mode)	Red	×
Mode 2 (American mode)	Red	Red
Mode 3 (European mode)	Green	×
Mode 4 (Chinese mode)	Green	Green

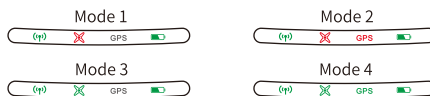



When the current mode is visible, you can change the mode by pressing . Press the button again and the current mode is selected. Press the button again to change to the next mode and press the button again to select that mode. When your preferred mode is shown, power off to complete the mode switching. After powering on the remote control is in your new preferred mode.



Reset the Wi-Fi range extender

Users can reset the Wi-Fi range extender in following situations:

- (1) No connection can be established with the range extender.
- (2) The Wi-Fi range extender password is unknown.

Steps to reset the Wi-Fi range extender:

- (1) Hold the left control stick in top right position and the right control stick in the top left position,  +  then power on the remote control to enter the test mode.
- (2) Release the sticks and wait until the Wi-Fi signal indicator is red.

- (3) Press “” to reset. The Wi-Fi indicator switches from red to yellow. Wait until it turns red again. The reset is completed.
- (4) Press the “” again and restart the remote control.
- (5) When the remote control is ready, enable Wi-Fi in your mobile device and search for the Wi-Fi network named “XPLORESER_XXXXXX”. When requested, enter the default range extender password “XIRO1234” and connect to the network.
- (6) the XIRO App settings section and connect the range extender to the network named “UG3300_XXXXXX”. Wait until the range extender is reconnected. The Wi-Fi indicator will turn green when the camera and range extender are connected successfully.

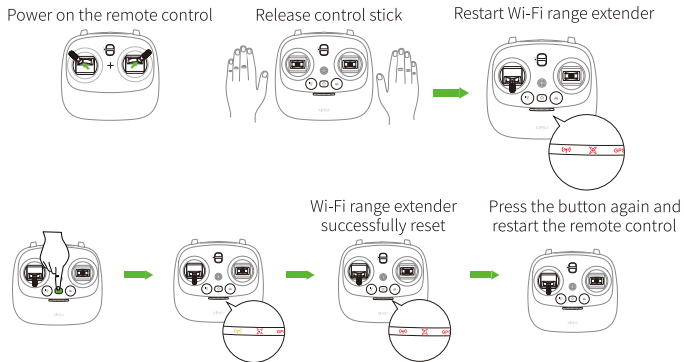

Connecting the Wi-Fi range extender to the camera

Users need to connect the Wi-Fi range extender to the camera when the Wi-Fi range extender or gimbal have been exchanged.

Steps to connect the range extender to the camera:

- (1) Install the range extender to the remote control and power on the remote control.
- (2) When the gimbal is successfully attached to the Xplorer, simultaneously press the camera Wi-Fi button on the front of the gimbal and power on the aircraft. Hold the camera Wi-Fi button for 3 seconds before releasing it.
- (3) Enable Wi-Fi in your mobile device and search for the Wi-Fi network named “XPLORESER_XXXXXX”. When requested enter the default range extender password “XIRO1234” and connect to the network.
- (4) Open the XIRO App settings section and connect the range extender to the network named “UG3300_XXXXXX”. Wait until the range extender is reconnected. The Wi-Fi indicator will turn green when the camera and range extender are connected successfully.

Calibrating the gimbal

When the gimbal behavior is abnormal or the auto calibration fails, users have to calibrate the gimbal manually.

Steps to calibrate the gimbal:

- (1) Uninstall the propellers and power on the remote control. Press the power button on the Xplorer and wait until the Xplorer is ready. (No. ①)
- (2) Press successively the IOC, the One-key return home and the One-key takeoff/landing buttons down into the on position. (No. ②)
- (3) Push down both the left scroll wheel (Flight indicators LED brightness control) and right scroll wheel (Camera pitch angle control) to the bottom and hold for 1 second. The gimbal will now switch into the power off state. It will no longer adjust itself. You can now release both scroll wheels on the remote control. (No. ③)
- (4) Attach the gimbal clamp to fixate the gimbal in the correct horizontal position. (No. ④)
- (5) Press after each other the IOC, the One-key return home and the One-key takeoff/landing buttons into the off position. The gimbal will now power on and calibrate the gimbal. Do not touch the camera or any buttons on the remote control.
- (6) Wait for 30s and power off the remote control and Xplorer. Remove the gimbal clamp and restart the Xplorer. The gimbal should now return into its stable active status.

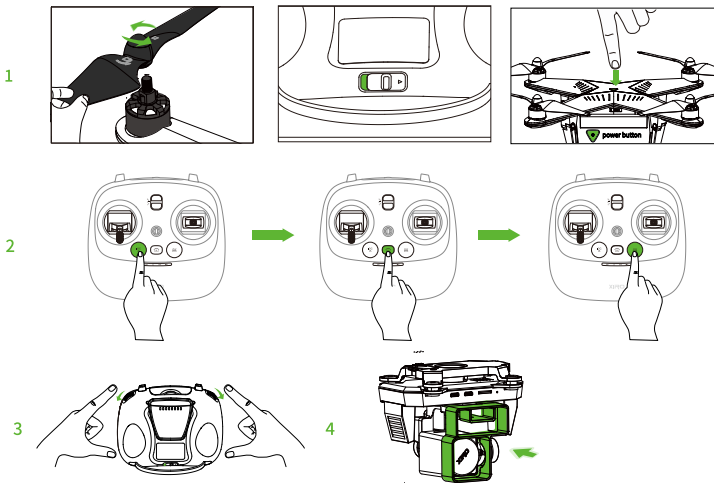

 Upgrade both the Xplorer and the gimbal firmware to the latest available version before the calibration procedure.

XIRO

 If you have any questions, we ask you to check our support pages on <http://xirodrone.com/support>. Here you will find our latest FAQ, Video tutorials and the contact details for our regional XIRO Service Centers.